

QUICKFLIGHT / QUICKFLIGHT XL FREE FALL DEVICE

Operator Manual

Models: QF150-12A / QFXL150-20A



NOTE TO OWNERS, INSTALLERS, AND OPERATORS

Always Read Instructions Before Use

The Operator Manual contains information relating to the proper installation, operation, and maintenance of the QuickFlight Free Fall Device and includes all product registration and warranty information. This document must be supplied to the Owner/Operator after installation. Ensure that this Operator Manual is readily available to responsible parties at all times.

Head Rush Technologies QuickFlight Free Fall Device Manual
P/N 18310-08

Head Rush Technologies products are covered by a number of patents, including
U.S. Patents 8,490,751; 8,851,235; 9,016,435 and D654,412 & corresponding patents/applications in the USA and in other countries worldwide.



QUICK FLIGHT

XL

hoodnub
parachute
harness

ANNUAL
INSPECTION

TABLE OF CONTENTS

<i>Important Safety Warnings</i>	5
<i>Health and Safety</i>	6
<i>Site Rescue Plan</i>	6
1.0 SAFETY INFORMATION	7
<i>Symbols Used in this Manual</i>	7
2.0 WARRANTY CONDITIONS	8
<i>2.1 Owner Responsibility</i>	8
3.0 CERTIFICATION	10
<i>3.1 Standards</i>	10
4.0 DESCRIPTION	11
5.0 SPECIFICATIONS	12
<i>5.1 All QuickFlight Models</i>	12
<i>5.2 Mounting Heights</i>	13
6.0 QUICKFLIGHT PARTS	15
<i>6.1 Labels</i>	16
<i>6.2 Icon Descriptions</i>	17
7.0 UNPACKING	19
<i>7.1 Precautions</i>	19
<i>7.2 Receipt of the QuickFlight Free Fall Device</i>	19
<i>7.3 Unpacking the QuickFlight Free Fall Device</i>	19
<i>7.4 Storage</i>	20
8.0 INSTALLATION	21
<i>8.1 Precautions</i>	21
<i>8.2 Standards</i>	21
<i>8.2.1 Anchor Points</i>	21
<i>8.2.2 Harness</i>	22
<i>8.2.3 Secondary Connectors</i>	22
<i>8.2.4 Selecting a Location</i>	23
<i>8.2.5 Outdoor Installations</i>	24
<i>8.2.6 Mounting Points</i>	24

8.2.7 Mounting Diagram	25
8.2.8 Location Diagram	26
9.0 OPERATION	27
9.1 Operator Training	28
9.2 User Instruction	28
9.3 Proper Harness Connections	31
9.4 Carabiner Operation	31
9.5 Proper Webbing Retraction	32
10.0 INSPECTION AND MAINTENANCE	33
10.1 Annual Recertification	33
10.2 Scheduled Maintenance	33
10.2.1 Safety Precautions	34
10.3 Daily Inspection	35
10.3.1 Upper Webbing Inspection	35
10.3.2 RipCord Webbing Inspection	40
10.4 Weekly Inspection	42
10.5 Bi-Annual Inspection	44
10.5.1 Inspection Procedure	44
10.6 Upper Webbing Replacement	45
10.7 Nozzle Replacement	48
10.8 Side Cover Replacement	49
10.9 RipCord Webbing Replacement	50
10.10 Long Term Storage	51
10.11 Replacement Part	52
10.12 Troubleshooting	52
10.13 Transportation	52
11.0 MANUFACTURER'S DETAILS	53
Address	53
Contact Details	53

Important Safety Warnings

READ BEFORE INSTALLATION & OPERATION



RECREATIONAL DESCENT IS A DANGEROUS ACTIVITY.

THE QUICKFLIGHT FREE FALL DEVICE IS PRIMARILY USED AS A RECREATIONAL FREE FALL DEVICE. IT CAN BE USED FOR CLIMBING PROTECTION. A MANDATORY FALL ATTENUATION SURFACE IS REQUIRED UNDER THE PARTICIPANT/CLIMBER AT ALL TIMES. ADDITIONAL CARE MUST BE TAKEN AT THE TOP OF THE CLIMB AS THE RIPCORD WILL PREVENT 100% OF THE WEBBING FROM RETRACTING. ADDITIONAL FREEFALL WHILE CLIMBING IS POSSIBLE, SO CARE AND TRAINING FOR PARTICIPANTS IS REQUIRED.

USE OF THE QUICKFLIGHT FREE FALL DEVICE FOR ANY PURPOSES OTHER THAN THOSE INTENDED BY THE MANUFACTURER ARE NOT PERMITTED AND MAY RESULT IN SERIOUS INJURY AND/OR DEATH.

PRIOR TO INSTALLATION AND OPERATION, ALL RESPONSIBLE PARTIES MUST HAVE READ AND SHOWN TO HAVE UNDERSTOOD ALL REQUIREMENTS, INSTRUCTIONS, LABELS, MARKINGS AND SAFETY INFORMATION PERTAINING TO THE CORRECT INSTALLATION, OPERATION, INSPECTION, AND MAINTENANCE OF THE QUICKFLIGHT FREE FALL DEVICE, ITS COMPONENT PARTS, AND ALL ASSOCIATED HARDWARE AND SYSTEMS. FAILURE TO DO SO MAY RESULT IN EQUIPMENT DAMAGE, SERIOUS INJURY, OR DEATH.

QuickFlight Free Fall Device Models QF150-12A, QFXL150-20A, and associated equipment are designed and specified for use as rapid descent devices.

Owners and Operators of the QuickFlight Free Fall Device are responsible for the safety and supervision of any person using the QuickFlight Free Fall Device and are required to ensure that proper installation, operation, and maintenance procedures are followed at all times. Proper installation requires careful design and planning using QuickFlight and non-QuickFlight components. Owners, Installers, and Operators are required by the Manufacturer to read, understand, and follow all instructions in this Operator Manual regarding the correct installation and operation of the QuickFlight Free Fall Device prior to any use. Owners and Operators are encouraged to seek the advice of their Installer or a qualified engineering professional regarding the instructions in this Manual.

These instructions must be made readily available to the Owners, Installers, and Operators of the QuickFlight Free Fall Device at all times. Prior to installation and use of the device, all Owners, Installers, and Operators must have read and shown to have understood all instructions, labels, markings, and safety information pertaining to the installation, operation, care, and maintenance of the QuickFlight Free Fall Device system, its component parts, and all associated hardware.

Health and Safety

Owners and Operators must abide by all Standards, International, Federal, State and Provincial laws, and any specific health and safety regulations pertaining to the installation and use of this product.

Site Rescue Plan

Owners and Operators must have devised an emergency rescue plan for any Participant in distress at all sites operating QuickFlight Free Fall Devices. Operators must inform Users of the QuickFlight Free Fall Device of the procedure for rescuing a Participant in distress prior to descent.

1.0 SAFETY INFORMATION

Symbols Used in this Manual

The following safety symbols are used throughout this manual to highlight potential dangers. One or more precautions may be associated with practices and procedures described within this manual. Failure to adhere to any precautions highlighted can result in death, serious injury, or equipment damage.

Ensure that you read and understand all safety procedures related to the working environment and the task you are performing.



DANGER

Indicates a hazardous situation exists that, if not avoided, will result in serious injury or death.



WARNING

Indicates a potentially hazardous situation that, if not avoided, could result in serious injury or death.



CAUTION

Indicates a potentially hazardous situation that, if not avoided, may result in injury or equipment damage.



NOTE

Indicates an action that must be taken to ensure personal safety and prevent damage to property or equipment.



CARE FOR THE ENVIRONMENT

Take care to minimize impact on the environment when carrying out this procedure.

2.0 WARRANTY CONDITIONS

This QuickFlight Free Fall Device is warranted against factory defects in materials and workmanship (excluding "Replacement Parts" – see below) for a period of two (2) years from date of purchase. This warranty applies only to the original purchaser, and is contingent upon the Owner/Operator maintaining and using the device in accordance with Manufacturer's instructions, including the requirement to continue to maintain annual recertification as described in the Operator's Instruction Manual. This Warranty is in lieu of all other warranties, express or implied.

The sole remedy for breach of this warranty, or for any claim in negligence or strict liability in tort, is the repair or replacement of any defective parts by Head Rush Technologies. Upon notice in writing, Head Rush Technologies will promptly repair or replace all defective items. Head Rush Technologies reserves the right to have any defective equipment returned to its plant, transportation pre-paid, for inspection before making a repair or replacement.

This Warranty is null and void if parts other than genuine parts are used, or if any modifications or services have been performed on the device by anyone other than an authorized service center. This warranty does not cover any damages resulting from abuse to the device, damage in transit, or any other damage beyond the control of Head Rush Technologies. Head Rush Technologies makes no warranties in respect to trade accessories or component parts which are not made by Head Rush Technologies. Head Rush Technologies expressly excludes from this Warranty the replacement of "Replacement Parts".

No person, agent or Distributor is authorized to give any warranty, other than the one herein expressed, on behalf of Head Rush Technologies, or to assume for it any liability pertaining to such products. Head Rush Technologies expressly disclaims any implied guarantee of merchantability, or claim as to whether the device is suited for a particular purpose. Purchaser agrees that Head Rush Technologies shall not be held liable to Purchaser/Operator for damages of any kind, including but not limited to, lost or projected profits, equipment down time, or any losses considered to be caused by non-operation or servicing/recertification down time of the equipment.

2.1 Owner Responsibility

The following items are considered to be the responsibility of the Owner/Operator and are therefore not reimbursable under the terms of the warranty.

- Routine maintenance and inspection.
- Normal replacement of service items.
- Replacements required because of abuse, misuse or improper operational habits of the Operator.

-
- Wearing parts such as nozzle, webbing lines, RipCord webbings, carabiners, attachment rings, side covers, and lanyard keepers.
 - Normal deterioration due to use and exposure.

This warranty is subject to the following of the requirements of the Operator Manual supplied, Manufacturer's instructions, and the advice given by Head Rush Technologies service technicians.

3.0 CERTIFICATION

3.1 Standards



NOTE

If the QuickFlight Free Fall Device is resold outside of the country of destination, the reseller must provide instructions for use, service, maintenance and repair in the language of the country of use.

The QuickFlight and the QuickFlight XL Free Fall Devices can be used as a climbing/descent/free fall system device only in combination with other components. It shall not be deemed suitable for use until it is ensured that the entire system complies with the requirements of appropriate regional, state, and federal directives/standards.

The QuickFlight and QuickFlight XL Free Fall Devices conform to Regulation (EU) 2016/425 and comply with the following prevailing Safety regulations:

- **AS/NZS 1891:** Industrial fall-arrest systems and devices – Part 3: Fall arrest devices
- **CSA Z259.2.3-99:** Descent Control Devices
- **EN 341: 2011 Class 1A:** Personal protective equipment against falls from a height – Descender devices
 - 3rd party tested to 10x Class A
- **ANSI/ASSE Z359.4:** Safety Requirements for Assisted-Rescue and Self-Rescue Systems, Subsystems and Components.
- **EN 360:2002:** Personal protective equipment against falls from a height - Retractable type fall arresters
 - **Section 4.5:** Maximum force <6kN for 130kg capacity

EU Declaration of Conformity:

EU Declaration of Conformity can be downloaded at this website address:
<https://headrushtech.com>

Body controlling the manufacture of this PPE:

TÜV SÜD Product Service GmbH
Ridlerstraße 65
80339 München, Germany

Notified body performing the CE type exam:

TÜV SÜD Product Service GmbH
Ridlerstraße 65
80339 München, Germany

4.0 DESCRIPTION



THE FIGURES PRESENTED IN THIS MANUAL ARE NOT TO SCALE AND MAY NOT SHOW ALL REQUIRED COMPONENTS OR STRUCTURES, INCLUDING, BUT NOT LIMITED TO: MOUNTING POINTS, CONNECTORS, SAFETY EQUIPMENT, ETC.

The QuickFlight Free Fall Device is a descent device designed specifically for use as a component within a free fall system or climbing system. The design of the QuickFlight Free Fall Device permits simple installation and removal and incorporates an advanced self-regulating brake system and automatic webbing line retraction. The patented braking mechanism offers Participants an initial free fall followed by a consistent descent with a minimal variation in descent rate of both children and adults.

Two models are available:

- QF150-12A QuickFlight Free Fall Device
- QFXL150-20A QuickFlight XL Free Fall Device

The QuickFlight Free Fall Device offers a standard free fall experience and may be mounted at a low height range. The QuickFlight XL Free Fall Device provides an extended free fall experience but must be mounted at a higher height range.

All QuickFlight Free Fall Devices use a unique dual webbing line configuration for added redundancy and lower cost of ownership. This webbing configuration uses two Upper Webbing lines that extend into and out of the Device and connect to a mandatory RipCord Lower Webbing. The RipCord also includes an Overload Protection Assembly (OPA) that provides additional safety in the event that the device ever stops functioning on descent.

Upper webbings are available in three lengths: Low Mount, Standard, and XL. The device should never be used with un-matched Upper Webbing lengths. Two RipCord variants are available: the 1m RipCord for a standard free fall experience or the 2m RipCord for an extended free fall experience. As with the Device and Upper Webbing selections, the RipCord length influences the required installation height. Refer to the full specifications based on your Device model, Upper Webbing length, and RipCord length for proper installation details.

To protect the longevity of the QuickFlight Free Fall Device, installation, care and use of the QuickFlight Free Fall Device must be carried out in accordance with the instructions in this manual. It is the responsibility of the Installer/Operator to ensure that an allowable webbing configuration is used in the device, and to always mount the QuickFlight Free Fall Device within the stated mounting height limits for the Upper Webbing, Lower Webbing, and Device combination used.

If the QuickFlight device is installed, used, and maintained in accordance with the instructions in this manual, its design lifespan is 15 years.

5.0 SPECIFICATIONS

Every QuickFlight Free Fall Device comes with two Upper Webbing and a RipCord assembly pre-installed. The Owner should keep the original packaging to use for storage and shipping of the device.

5.1 ALL QUICKFLIGHT MODELS

CERTIFICATION	IN ACCORDANCE WITH EN 341:2011-1A AND EN 360:2002		
DIMENSIONS	0.43 x 0.33 x 0.25 m (17 x 13 x 10 in)		
DISTANCE	NOZZLE TO PRIMARY MOUNTING POINT	0.405 m (15.94 in)	
NET WEIGHT	25 kg (55 lbs)		
MATERIALS	CASING	Aluminum Alloy	
	INTERNAL PARTS	Zinc plated steel Stainless steel	
	NOZZLE	Modified Acetal plastic	
	NOZZLE INSERT	304 Stainless Steel	
	LINE	Polyamide/Ultra High Molecular Weight Polyethylene	
	CONDI- TION	MINIMUM	MAXIMUM
USER WEIGHT	----- ----	20 kg (44 lbs)	130kg (285 lbs)
OPERATING TEMPERATURE	ANY	-4° C (25° F)	60° C (140° F)
	DRY	-10° C (14° F)	60° C (140° F)
STORAGE TEMPERATURE	----- ----	-20° C (-4° F)	60° C (140° F)
LANDING SPEED	----- ----	0.5 m/s (1.6 ft/s)	2.0 m/s (6.6 ft/s)



METRIC UNITS ARE THE CONTROLLING UNITS OF MEASURE IN THIS MANUAL. IMPERIAL UNITS ARE PROVIDED AS A COURTESY AND HAVE BEEN ROUNDED. IF THE OWNER/OPERATOR/INSTALLER MUST MAKE ANY UNIT CONVERSIONS, THE METRIC UNITS SHOULD BE REFERENCED.

5.2 MOUNTING HEIGHTS

Nozzle to Platform

MODEL	MINIMUM	MAXIMUM
ALL MODELS	1.75 m (5.7 ft)	2.50 m (8.2 ft)

QuickFlight Standard Free Fall Device, QF150-12A

MODEL	MINIMUM	MAXIMUM
LOW MOUNT UPPER WEBBINGS & 1 M RIPCORD	6.0 m (19.7 ft)	8.3 m (27.2 ft)
12 M UPPER WEBBINGS & 1 M RIPCORD	8.0 m (26.2 ft)	14.3 m (46.9 ft)
12 M UPPER WEBBINGS & 2 M RIPCORD	9.0 m (29.5 ft)	15.3 m (50.2 ft)

QuickFlight XL Free Fall Device, QFXL150-20A

MODEL	MINIMUM	MAXIMUM
20 M UPPER WEBBINGS & 1 M RIPCORD	12.0 m (39.4 ft)	21.8 m (71.5 ft)
20 M UPPER WEBBINGS & 2 M RIPCORD	13.0 m (42.7 ft)	23.0 m (75.5 ft)

* Mounting heights are from nozzle to landing zone and may vary with the addition of authorized QuickFlight accessories.

QuickFlight Webbing Configurations

		1M RIPCORD	2M RIPCORD
QUICKFLIGHT	LOW MOUNT		
	STANDARD		
QUICKFLIGHT XL			



THE QUICKFLIGHT FREE FALL DEVICE WITH LOW MOUNT UPPER WEBBINGS MAY NOT BE USED WITH THE 2M RIPCORD. ENSURE THAT AN ALLOWABLE COMBINATION OF DEVICE, UPPER WEBBINGS, RIPCORD WEBBINGS, AND MOUNTING HEIGHT IS IN PLACE BEFORE LIVE OPERATION OF THE QUICKFLIGHT FREE FALL DEVICE.

6.0 QUICKFLIGHT PARTS

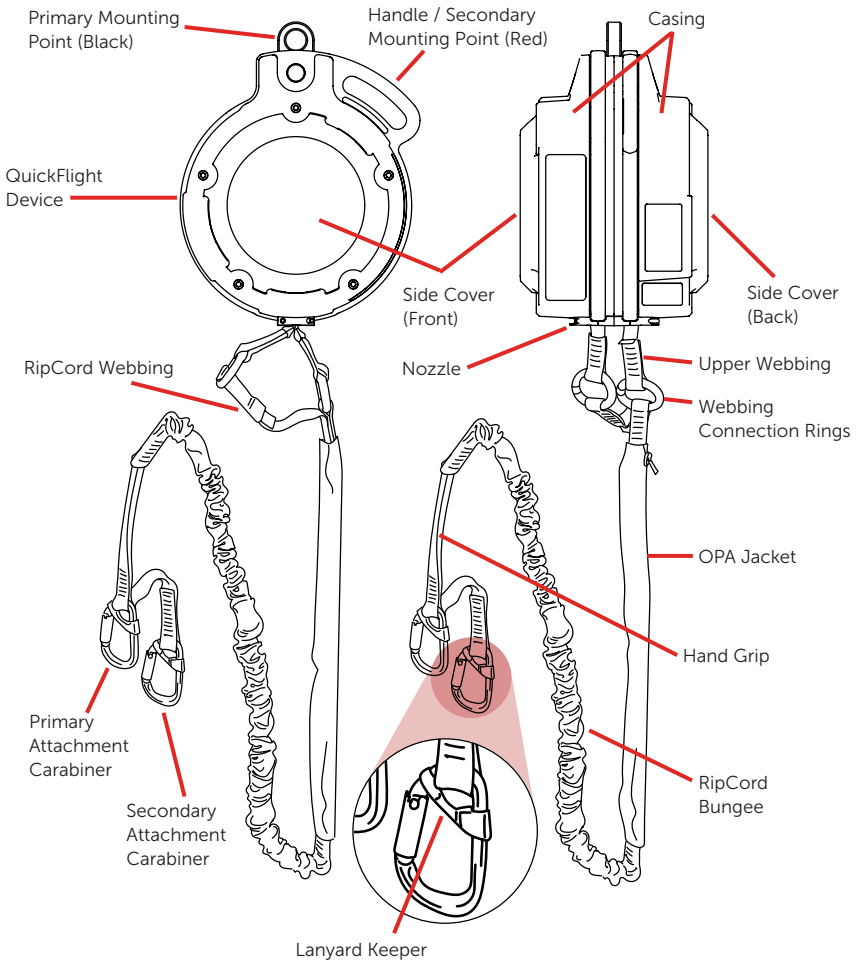

6.1 Labels

INFORMATION LABEL

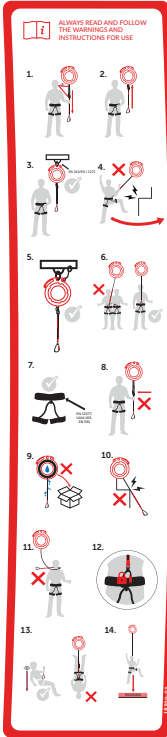

SERIAL LABEL
QF150-12A SN QF00000
QFXL150-20A SN QFXL00000

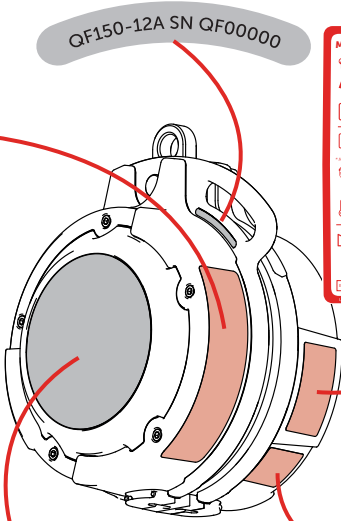

SPECIFICATION LABEL
(VARIES BY MODEL)

MODEL: QFXL150-20A

RATED BODY WEIGHT:
25 to 220 lbs (11.3 to 100 kg)

DEVICE WEIGHT:
15.5 to 25.5 lbs (7.0 to 11.6 kg)

MOUNTING HEIGHT:
25 ft (7.6 m) max
24 ft (7.3 m) max
23 ft (7.0 m) max
22 ft (6.7 m) max
21 ft (6.4 m) max
20 ft (6.1 m) max
19 ft (5.8 m) max
18 ft (5.5 m) max
17 ft (5.2 m) max
16 ft (4.9 m) max
15 ft (4.6 m) max
14 ft (4.3 m) max
13 ft (4.0 m) max
12 ft (3.7 m) max
11 ft (3.4 m) max
10 ft (3.1 m) max
9 ft (2.8 m) max
8 ft (2.5 m) max
7 ft (2.2 m) max
6 ft (1.9 m) max
5 ft (1.6 m) max
4 ft (1.3 m) max
3 ft (1.0 m) max
2 ft (0.7 m) max
1 ft (0.4 m) max

LANDING SPEED:
10 ft/s (3.0 m/s) max

TEMPERATURE RANGE:
Operating: 0°C to 40°C (32°F to 104°F)
Storage: -20°C to 60°C (-4°F to 140°F)

TRUBLUE TECHNOLOGIES
1800 Cherry Street, Suite C
Culverton, California 92522, USA
www.headrushtech.com

CE 0123

MODEL: QF150-12A

RATED BODY WEIGHT:
25 to 220 lbs (11.3 to 100 kg)

DEVICE WEIGHT:
15.5 to 25.5 lbs (7.0 to 11.6 kg)

MOUNTING HEIGHT:
25 ft (7.6 m) max
24 ft (7.3 m) max
23 ft (7.0 m) max
22 ft (6.7 m) max
21 ft (6.4 m) max
20 ft (6.1 m) max
19 ft (5.8 m) max
18 ft (5.5 m) max
17 ft (5.2 m) max
16 ft (4.9 m) max
15 ft (4.6 m) max
14 ft (4.3 m) max
13 ft (4.0 m) max
12 ft (3.7 m) max
11 ft (3.4 m) max
10 ft (3.1 m) max
9 ft (2.8 m) max
8 ft (2.5 m) max
7 ft (2.2 m) max
6 ft (1.9 m) max
5 ft (1.6 m) max
4 ft (1.3 m) max
3 ft (1.0 m) max
2 ft (0.7 m) max
1 ft (0.4 m) max

LANDING SPEED:
10 ft/s (3.0 m/s) max

TEMPERATURE RANGE:
Operating: 0°C to 40°C (32°F to 104°F)
Storage: -20°C to 60°C (-4°F to 140°F)

TRUBLUE TECHNOLOGIES
1800 Cherry Street, Suite C
Culverton, California 92522, USA
www.headrushtech.com

CE 0123

head rush technologies

SERIAL NUMBER:

MANUFACTURE DATE: / /

REGISTRATION CODE: / /

BEST BESET NUMBER: / /

↑ ? m:

1800-00

CERTIFICATION LABEL



COVER LABEL (BOTH SIDES, VARIES BY MODEL)

head rush technologies









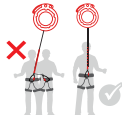

MADE IN USA

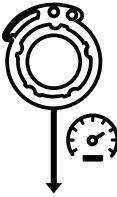



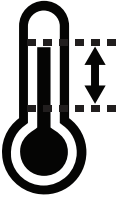





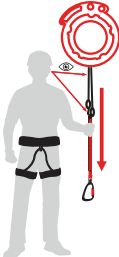
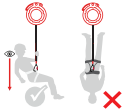

YYYY

Jan.	Feb.	Mar.
Apr.	May	Jun.
Jul.	Aug.	Sept.
Oct.	Nov.	Dec.

WEBBING DATE OF MANUFACTURE LABEL (Attached to Webbing)

6.2 Icon Descriptions

	<p>Device Weight</p>		<p>Only one user at a time</p>
	<p>Body Weight</p>		<p>Harness standards</p>
	<p>Landing Speed</p>		<p>Do not alter the line. Do not clamp, knot or tie on additional line</p>
	<p>Country of Manufacture</p>		<p>Do not store the line inside the device wet</p>
	<p>Temperature Range</p>		<p>Never install the device where the line passes over sharp edges, high friction areas</p>
	<p>Minimum Height</p>		<p>Never permit line to wrap around or become entangled with neck, arms, or legs</p>

	<p>Maximum Height</p>		<p>Connect the carabiner to the designated belay loop of your harness, making sure the gate is locked</p>
	<p>Inspect the Webbing</p>		<p>Check descent path is clear, Always land with slightly bent knees to absorb landing</p>
	<p>Both lines must be fully retracted before use.</p>		<p>Fall attenuation surface required</p>
	<p>Minimum connector strength for installation</p>		<p>Serial number</p>
	<p>Avoid swing falls into objects</p>		<p>Manufacture Date</p>
	<p>Primary connector taut, secondary back-up connector loose</p>		<p>Date</p>
			<p>Technician</p>

7.0 UNPACKING

7.1 Precautions



LEAVE THIS OPERATOR MANUAL ATTACHED TO THE QUICK-FLIGHT UNTIL INSTALLATION IS COMPLETE

The Operator Manual contains information relating to the safe use of the QuickFlight Free Fall Device and includes all product registration and warranty information. The Operator Manual may only be removed by the owner/operator. Ensure this manual is readily available to Free Fall Device users at all times.



DO NOT DISPOSE OF PACKAGING

The cardboard box and internal packaging are required for the return of the Free Fall Device for the annual Certification inspection. Please keep packaging in a safe place until required.

7.2 Receipt of the QuickFlight Free Fall Device

The QuickFlight Free Fall Device is packaged in a recycled cardboard box and contains:

- 1 x QuickFlight Free Fall Device with Upper Webbing Installed (model and Upper Webbing will vary depending on the specifics of your order)
- 1 x RipCord Assembly (length will vary depending on the specifics of your order)
- 2 x Webbing Connection Rings
- 2 x Carabiners
- 2 x Lanyard Keepers (Installed on Carabiners)
- 1 x Operator Manual

The QuickFlight Free Fall Device is shipped with the webbing lines and carabiners attached and does not require any further assembly.

7.3 Unpacking the QuickFlight Free Fall Device

To unpack the QuickFlight Free Fall Device:

1. Upon receipt of QuickFlight Free Fall Device, inspect for signs of shipping damage or contamination. If QuickFlight Free Fall Device shows any signs of damage or mishandling, contact your Head Rush Technologies distributor.
2. Check that all labels shown in this manual are properly affixed to the QuickFlight Free Fall Device and are legible.

3. Check the Certification Label for the 'Next Recertification Required' date. If the date shown has passed or the label is missing or illegible the QuickFlight Free Fall Device must not be put into service.
4. Register your QuickFlight Free Fall Device online at www.headrushtech.com/registration
5. Read the Operator Manual and familiarize yourself with all aspects of installation, operation, care and maintenance.



THE QUICKFLIGHT DEVICE IS HEAVY. USE CARE WHEN LIFTING! DROPPING OR HARD IMPACTS TO THE QUICKFLIGHT FREE FALL DEVICE CAN RESULT IN SERIOUS DAMAGE TO MOUNTING POINTS AND INTERNAL PARTS AND MAY COMPROMISE SAFETY OF OPERATION. IF THE QUICKFLIGHT FREE FALL DEVICE IS SUBJECTED TO A HARD IMPACT, REMOVE IT FROM DUTY AND RETURN TO AN AUTHORIZED SERVICE CENTER FOR INSPECTION.

7.4 Storage

If the Free Fall Device is to be left unused for longer than two weeks, ensure the unit is clean and dry and line is fully retracted into the unit.

When returning the Free Fall Device to duty after an extended period of inactivity, always carry out a full inspection and operational check.



DO NOT STORE IN WET CONDITION

After exposure to water or damp conditions thoroughly clean and dry the Free Fall Device. Ensure Free Fall Device is not left with wet webbing line retracted inside the casing. If the webbing is wet and the device is to be stored, remove the nozzle and pull all the webbing out until the shackle is exposed. Insert a pin through the line to prevent retraction, and allow the webbing to dry naturally away from open fire or heat source.

Always store in a clean and dry environment.

8.0 INSTALLATION

8.1 Precautions



ALWAYS USE DESIGNATED MOUNTING POINTS

Never install the Free Fall Device using any part of the device apart from the designated mounting points. Incorrect mounting can result in serious injury or death.



ALWAYS USE THE CORRECT MOUNTING HEIGHT

Failure to install the device at the correct mounting height could result in damage to the device or loss in device performance, serious injury or death.



HARD IMPACTS MAY RESULT IN STRUCTURAL DAMAGE

Dropping of, or hard impacts to, the Free Fall Device can result in serious damage to mounting points and internal parts and may compromise safety of operation. If the Free Fall Device is subject to a hard impact, remove it from duty and return to a service agent for inspection.



HEAVY ITEM - 25 KG (55 LBS)

Take care when lifting the Free Fall Device. Take care not to drop the device as this may result in serious injury or equipment damage.



ALWAYS MOUNT VERTICALLY

Always mount the Free Fall Device vertically with the nozzle pointing downwards and the line exiting the bottom of the device. Failure to do so will result in incorrect operation and compromise User safety.



HARMFUL CONTACT

Do not allow solvents, acids, sharp edges etc. to get into contact with the device, especially the webbing. If in contact, the Free Fall Device must be inspected.

8.2 Standards

Prior to installation, all Operators must be familiar with the requirements of all relevant Standards for anchor points, hardware and equipment used with the Free Fall Device.

8.2.1 ANCHOR POINTS

At least two anchor points must be used to mount the QuickFlight Free Fall Device. Do not attach Primary and Secondary Mounting Points to the same anchor point. All anchor points and connectors used with a QuickFlight Free Fall Device must conform to any federal or state requirements for such devices.

Head Rush Technologies requires anchor points to have a minimum load capacity of 12 kN (2640 lbs) in expected directions of application. Other national and international standards for anchor points may apply and require higher load capacity. Consult with the authority having jurisdiction for your required load capacity.

The location and anchor points for the QuickFlight Free Fall Device should comply with the following:

- Anchor points are not to be used by additional devices or as attachments for hardware not associated with the Free Fall Device installation.
- Anchor points should be of a suitable size to correctly install any mounting hardware.

8.2.2 HARNESS

All harnesses used in conjunction with the QuickFlight Free Fall Device must comply with one or more of the following standards or an equivalent standard for your jurisdiction:

- EN 361 - Personal protective equipment for prevention of falls from a height – Full body harness.
- EN 813 - Personal protective equipment for prevention of falls from a height – Sit harness.
- EN 12277 - Type A. Full Body Harness.
- EN 12277 - Type B. Small Full Body Harness.
- EN 12277 - Type C Sit Harness.

Harnesses must be of the correct size and fitment and be in serviceable condition.

8.2.3 SECONDARY CONNECTORS

All secondary connectors and hardware used in the installation of the QuickFlight must conform to the requirements of:

- EN 362 - Types of connectors for personal protection.
- EN 12275 - Types of connectors for mountaineering.

All connectors, hooks, D-rings and shackles used to mount the QuickFlight must be of compatible size, shape and strength for the mounting point to which they are attached.



IT IS THE OWNER/INSTALLER'S RESPONSIBILITY TO ENSURE COMPATIBILITY OF CONNECTORS IN DEVELOPING THE HARNESS/CONNECTION SAFETY SYSTEM. INCOMPATIBLE CONNECTIONS CAN RESULT IN SERIOUS INJURY OR DEATH DUE TO UNINTENTIONAL DISCONNECTION DURING FREE FALL/DESCENT.

Two EN 362 certified triple locking carabiners are installed on the primary and secondary attachment points of the RipCord assembly for Participant connection. Two plastic Lanyard Keepers prevent the carabiners from rotating within their attachment points. Two EN 362 certified attachment rings are installed to connect the RipCord to the two Upper Webbing. The carabiners, lanyard keepers, and webbing connection rings must be checked and be in serviceable condition according to the Manufacturer's instructions before any use. Ensure the carabiners are only loaded along the vertical direction (i.e. not cross loaded).

The carabiners can be replaced with other EN 362 certified connectors at the Owner/Installer/Operator's discretion with the following requirements:

- If a continuous or smart belay system (or any other system) lengthens the distance between the Participant and the attachment points of the RipCord, the minimum Nozzle to Platform distance must be increased by the amount the connection is lengthened. The maximum Nozzle to Platform distance may be increased by the same amount.
- The Participant must remain connected to both the Primary and Secondary attachment points of the RipCord.
- Any connector utilized must be suitably rated and meet the requirements of any applicable international, federal, state or provincial standards for its application.
- When connections are made using carabiners, only triple locking carabiners with a lanyard retaining feature are to be used. Head Rush Technologies recommends the use of the Petzl Am'D carabiner with Captiv lanyard keeper.
- Connections to the QuickFlight and QuickFlight XL webbing assembly have the potential for additional wear and must be included in daily webbing inspections.

8.2.4 SELECTING A LOCATION



A PROTECTIVE FALL ATTENUATION SURFACE MUST BE USED AND CENTERED BELOW THE LANDING POINT OF THE DEVICE, EXTENDING AS REQUIRED TO ADEQUATELY PROTECT PARTICIPANTS FROM INJURIES. IT IS RECOMMENDED THE SURFACE MEET ASTM F1292 SPECIFICATION OR EN 1177 DEPENDING ON THE AUTHORITY HAVING JURISDICTION FOR IMPACT ATTENUATION OF SURFACING MATERIALS FOR A CRITICAL FALL HEIGHT OF 3M (9.8FT). THE SURFACE MUST BE AT LEAST 2.5M X 2.5M IN SIZE. A LARGER SURFACE MAY BE REQUIRED IF THE DEVICE IS OPERATED IN WINDY CONDITIONS.

When selecting a location to install the QuickFlight Free Fall Device, check:

- Install the device where it can be safely reached for inspections and servicing.
- The QuickFlight Free Fall Device will hang vertically over the line of descent with the nozzle pointing down. Ensure that the line of descent has full clearance from obstacles and pedestrians within its fully extended range, including areas to which the Participant may swing.
- The webbing must not come in contact with the structure.
- Ensure that descending on the device cannot cause the Participant to experience dangerous pendulum swings into adjacent obstacles, even in windy conditions.
- Orient the device so that when participants jump, the FACE of the webbing is loaded, not the EDGE. If loading the EDGE, there will be accelerated webbing wear.

8.2.5 OUTDOOR INSTALLATIONS

The QuickFlight Free Fall Device may be installed outdoors.

It is recommended that in wet or high-variable temperature environments, the Free Fall Device is protected from the direct ingress of water or foreign objects.



NOTE

Prolonged exposure to the elements will increase the risk of internal corrosion and degradation of the webbing line, resulting in increased operation and servicing costs. Increased inspections are required in these types of environments.

8.2.6 MOUNTING POINTS

With a suitable location for the QuickFlight Free Fall Device selected the device must be mounted only using the methods and hardware described in this manual. When mounting the QuickFlight Free Fall Device, be aware of the following precautions:

DEVICE MOUNTING POINTS



USE ONLY THE DESIGNATED MOUNTING POINTS

Use only the correct mounting points. Use of incorrect points can result in equipment damage.

Ensure all mounting hardware is secure but free to pivot in mounting point.

The QuickFlight Free Fall Device provides color-coded mounting points to ensure that it hangs centrally and vertically with the webbing line nozzle pointing down. The black Primary Mounting Point should be used to hold the weight of the device and all associated forces. The red Secondary Mounting Point should be connected for redundancy using hardware that can withstand all associated forces, but with no tension during normal operation. For optimal webbing life, it is important to mount the device in a way that loads the Primary Mounting Point without actively loading the Secondary Mounting Point.

8.2.7 MOUNTING DIAGRAM

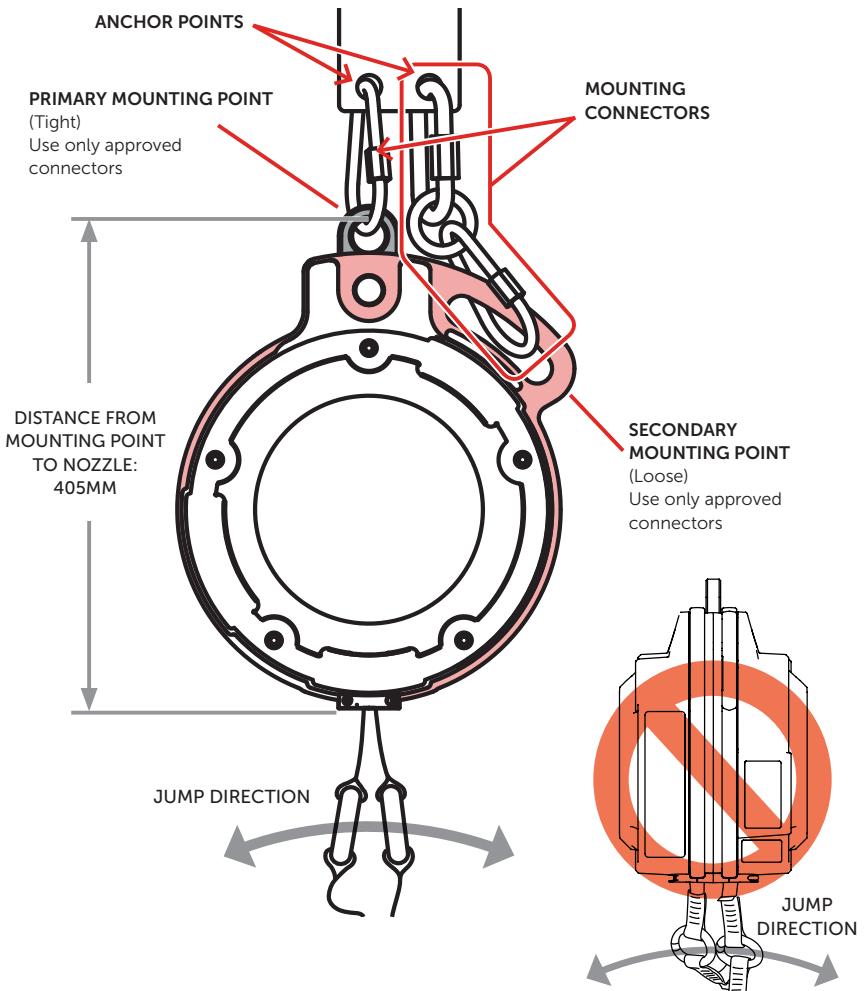

8.2.8 LOCATION DIAGRAM

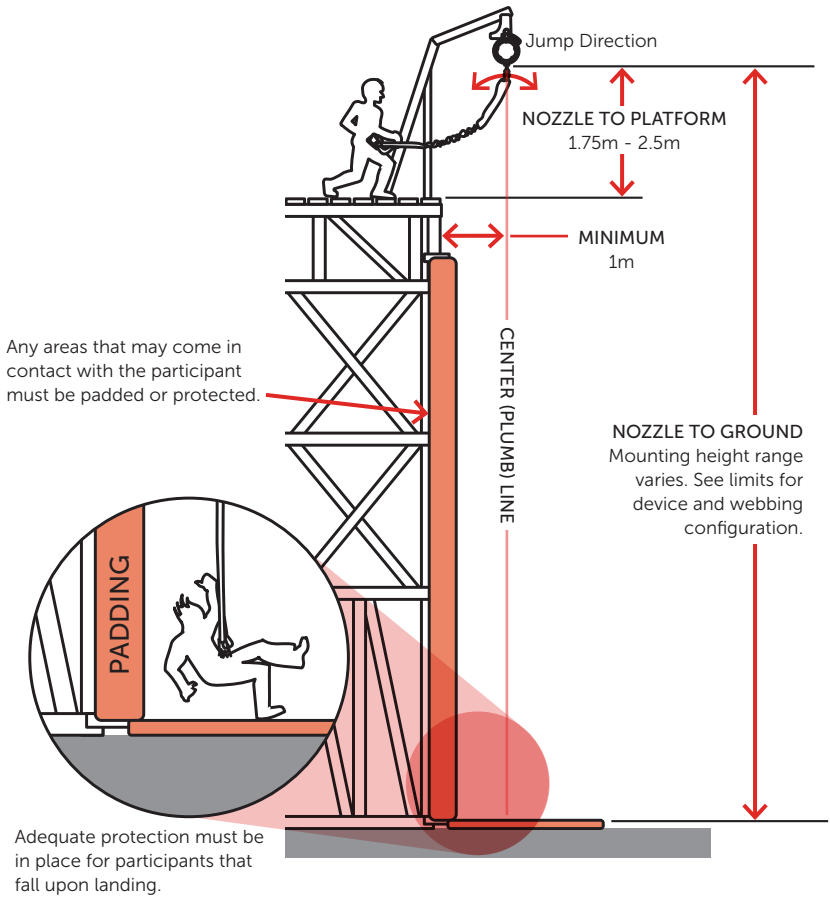

9.0 OPERATION

Owners and purchasers of the QuickFlight Free Fall Device are responsible for the safety and supervision of any person using this equipment and are required by the manufacturer to read, understand and follow all instructions in this Operator Manual regarding the correct installation and operation of the Free Fall Device prior to any use.



UNSAFE OPERATION

Remove Free Fall Device from service immediately if there is any concern over its correct operation or user safety.

Do not return Free Fall Device to service until it has been inspected and completed a recertification inspection and tested by an approved Head Rush Technologies Service Agent.



EMERGENCY RESCUE PLAN

Owners and operators must have devised an emergency rescue plan for any user in distress at all sites operating QuickFlight and QuickFlight XL Free Fall Devices. Operators must inform Users of the Free Fall Device of the procedure for rescuing a participant in distress prior to use.



STOP USE IMMEDIATELY IF ANY OF THE FOLLOWING OCCUR:

- Excessively fast webbing wear is noticed. Check unit mounting and replace webbing. Place the device back in service and check that fast webbing wear is resolved.
 - The landing speed increases from its normal level. Wait for the device to cool down. Place the device back in service if landing speed has returned to its normal level.
 - The device stops retracting webbing. Send the unit in for service.
-



EXTERNAL ITEMS PREVENTING RETRACTION

Any device that fails to retract or keep pace with the climber must be removed immediately from service and diagnosed by the operator. If items external to the device (see below for examples) are responsible for retraction problems, these must be corrected before placing the QuickFlight and QuickFlight XL devices back into service. If items external to the device have been removed, and retraction problems persist, immediately send the device to your nearest authorized service center.

Examples of external items that could prevent or affect retraction of a QuickFlight and QuickFlight XL devices:

- Foreign bodies becoming lodged in the nozzle.
 - Route marking tape interfering with the webbing and/or becoming lodged in the nozzle.
 - Protruding handholds, climbing wall features or climbing equipment interfering with lanyard retraction.
-

9.1 Operator Training

All personnel involved in the operation of the Free Fall Device must be trained and deemed competent in the following aspects of QuickFlight Free Fall Device operation;

- Transportation and storage.
- Installation, use of attachment points and attachment methods and hardware.

Inspection, cleaning, and scheduled servicing of the Free Fall Device, its component parts and associated attachment hardware.

9.2 User Instruction



NEVER USE WITHOUT BEING CORRECTLY ATTACHED

Ensure the carabiner is attached to the belay loop of the harness or other approved anchor point and the latch is fully closed and the gate engaged before use. A gate check must be performed after every connection.

Failure to do so can result in serious injury or death.



WARNING

If you have any physical or medical conditions that may affect your proper use of the device, consult a medical professional prior to participation.



POTENTIAL FOR PARTICIPANT ENTANGLEMENT

Potential for participant entanglement exists during descent. Ensure all loose items that may become tangled are tightened or removed before using the QuickFlight. A risk assessment should be completed at the installation site to determine the necessary PPE for users.

Prior to clipping in, all Participants must be instructed in the proper and correct use of the QuickFlight Free Fall Device. Operators are to ensure all Participants are familiar with the site rescue plan in the event the Participant becomes distressed.

Prior to descent, the Participant and Operator must be aware of, completely understand, and obey the following precautions:

- Check Free Fall Device operation by pulling out a short section and allowing it to retract.
 - If the Free Fall Device stops retracting for any reason while attached, STOP CLIMBING. If there is no slack in the line, jump onto the webbing and the Free Fall Device will descend. Notify the operator immediately.
 - If the Free Fall Device line fails to retract, do not clip into the Free Fall

Device and request assistance.

- Ensure that the daily device inspection has been performed and that the webbing line, carabiners, and device have not been damaged.
- Use a helmet if determined necessary by a qualified person.
- Do not allow Participants to descend with sharp objects (i.e. keys) in pockets.
- Ensure that Operators are anchored to the platform at all times. Participants must be anchored to the platform **AND** attached to the QuickFlight **UNTIL THEY ARE READY** to descend.
- Never push a reluctant Participant as this can create imbalance and improper orientation during free fall.
- Never continue operation if the webbing lines fail to fully retract. The webbing lines are considered to be fully retracted when at least one colored webbing end is touching the webbing nozzle and the other colored webbing end is less than 0.3m (1 ft) from the webbing nozzle. **DO NOT** pull out any excess webbing line prior to descent. The webbing line must be fully retracted or under tension prior to operation.
- Check the harness is correctly fitted and tightened.
- Check that the carabiners from the QuickFlight Free Fall Device line are connected to fall arrest attachment point(s) on the Participant harness as designated by the harness manufacturer, and that the gates are properly closed.
- Pay attention to the difference in locations of the primary and secondary carabiners when making harness connections! The primary carabiner is on the shorter attachment of the RipCord Webbing and should transmit all loading under normal operation. The secondary carabiner is on the longer attachment of the RipCord Webbing and should remain slack through normal operation.
- If both the primary and secondary carabiners are attached to the same harness attachment point, the carabiner gates should face opposite and opposed. Head Rush Technologies recommends that the primary carabiner latch gate faces outward away from the Participant and the secondary carabiner latch gate faces inward toward the Participant when the webbing is tensioned, when specific harness connection points allow.
- If the primary and secondary carabiners are attached to different harness attachment points, the carabiner latch gates should both face outward from the Participant when the webbing is tensioned.
- Attach the primary carabiner and the secondary carabiner onto the harness attachment points in a way that does not load the secondary carabiner during normal operation.

- Never pass the attachment points of the RipCord Webbing through any loops on the harness.
- Attach both carabiners to either the front attachment points or the rear attachment points of a harness. Never attach the carabiners on both the front and back of the harness, and never attach the carabiners to the side of the harness.
- Keep fingers clear of carabiners and harness attachment points when descending. Loading may cause pinching.
- Never permit the webbing lines to wrap around or rub against the legs, arms, neck, other body parts or loose clothing of the Participant prior to or during descent.
- Never descend from alongside or above the QuickFlight Free Fall Device.
- Prior to descent, ensure descent path and landing area are free of people and obstructions.
- When ready to descend, the Participant must be disconnected from any platform anchor, and must step straight down off the platform.



NEVER DESCEND WITHOUT BEING CORRECTLY ATTACHED! ENSURE CARABINERS ARE ATTACHED TO DESIGNATED ATTACHMENT POINTS OF THE HARNESS, THE LATCHES ARE FULLY CLOSED AND THE GATES ENGAGED IMMEDIATELY BEFORE DESCENT. A GATE CHECK MUST BE PERFORMED WHERE THE GUIDE APPLIES PRESSURE TO THE GATE OF THE CARABINER TO ENSURE THAT IT IS FULLY LOCKED. FAILURE TO DO SO CAN RESULT IN SERIOUS INJURY OR DEATH.

- The Participant should only hold on to the RipCord webbing by the hand grip.
- Always descend feet first and straight down using feet to fend off obstacles and prepare for landing.
- Upon landing, unclip the carabiners from the harness and allow the device to take up slack in the webbing and create tension before releasing the webbing line to be retracted freely and fully back into the QuickFlight Free Fall Device.



IF THE WEBBING LINES DO NOT RETRACT ENTIRELY INTO THE DEVICE, FULLY EXTEND BOTH WEBBING LINES AND ALLOW THEM TO SLOWLY RETRACT WHILE MAINTAINING CONSTANT TENSION. DO NOT ATTEMPT TO PUSH WEBBING BACK INTO THE NOZZLE DURING RETRACTION. IF THE WEBBING CONTINUALLY FAILS TO RETRACT, CONTACT AN AUTHORIZED SERVICE CENTER FOR REPAIR.

- Do not store wet webbing in the device. If webbing becomes wet, extend the lines and allow them to dry fully. Do not speed drying with heat.

9.3 Proper Harness Connections

WAIST CONNECTION



Primary carabiner on waist attachment with gate facing away from participant.

Secondary carabiner on waist attachment with gate opposite primary carabiner.

CHEST AND WAIST CONNECTION



Both carabiners on separate attachment points with gate facing away from participant. Primary carabiner connected lower than secondary carabiner.



DO NOT REVERSE THE CONNECTION.

DORSAL CONNECTION

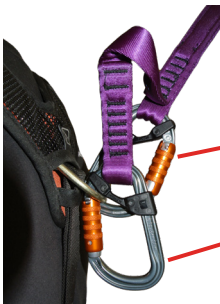

Primary carabiner on dorsal attachment with gate facing away from participant.

Secondary carabiner on dorsal attachment with gate opposite primary carabiner.

9.4 Carabiner Operation

If not using the carabiners supplied with the QuickFlight Free Fall Device, refer to the appropriate connector's User Instructions.

The supplied carabiners use a triple-action gate and are opened by sliding the gate's collar, rotating the gate's collar, and then pushing the gate toward the center of the carabiner.

The carabiners are closed by releasing the gate and allowing it to snap shut, ensuring the collars have rotated back and slid back to their fully locked position. Ensure that no clothing, webbing, incompatibly shaped D-rings, or other objects are obstructing the gate or its latching function.



Step 1 – Slide



Step 2 - Twist

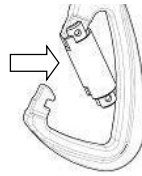

Step 3 – Depress



Step 4 – Release

9.5 Proper Webbing Retraction



INCORRECT

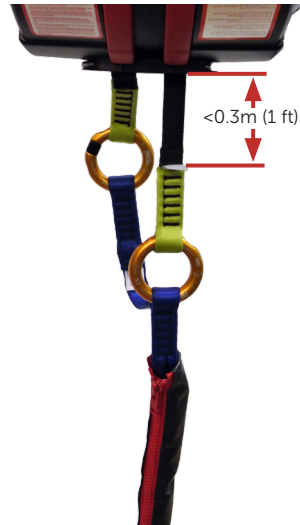

CORRECT



DO NOT ATTEMPT TO ASSIST THE RETRACTION OF THE WEBBING FOR ANY REASON. DOING SO COULD LEAD TO A DANGEROUS BINDING OF THE WEBBING WHICH CAN ABRUPTLY SHORTEN THE LIFE OF THE WEBBING.

10.0 INSPECTION AND MAINTENANCE

10.1 Annual Recertification



DO NOT OPERATE AFTER THE DATE SHOWN ON THE CERTIFICATION LABEL

Operation of a QuickFlight Free Fall Device without a current Certification Label visible is strictly forbidden. Severe bodily injury or death may occur.

The QuickFlight Free Fall Device requires an annual service and recertification inspection to be carried out by an authorized service center.

The Certification expiration date is shown on the Certification Label located on the side of the front casing. Dismount the Free Fall Device and return to the Manufacturer at the address shown at the back of this Manual or to an Authorized Service Center prior to the expiration date.



Do not use the Free Fall Device after date shown here.



ALL QUICKFLIGHT FREE FALL DEVICES MUST BE INSPECTED AND MAINTAINED IN ACCORDANCE WITH THIS MANUAL. FAILURE TO PERFORM SCHEDULED MAINTENANCE AND INSPECTIONS ON THE QUICKFLIGHT FREE FALL DEVICE MAY RESULT IN SERIOUS INJURY OR DEATH. DO NOT ATTEMPT TO CARRY OUT ANY MAINTENANCE, REPAIR, OR SERVICE ACTIONS NOT DETAILED IN THE USER MANUAL. ANY UNAUTHORIZED MAINTENANCE, REPAIR, OR MODIFICATIONS TO THE QUICKFLIGHT FREE FALL DEVICE WILL COMPROMISE SAFETY, RENDER THE DEVICE NOT FIT FOR USE, AND VOID THE WARRANTY.

10.2 Scheduled Maintenance

The following inspection and service actions must be carried out by the operator or operator-trained staff. All personnel performing these actions must be trained in the correct procedures and deemed competent to do so.



NO UNAUTHORIZED SERVICING

Do not attempt to carry out any maintenance, repair or service actions not detailed in the Operator Manual.

Any unauthorized maintenance, repair or modifications to the Free Fall Device will compromise safety, render the unit not fit for use, and void the warranty provisions.



NOTE

Service in a clean environment. If Free Fall Device has been removed from its operational location for service, ensure that the service area is clean and free from contaminants.

Ensure unit is securely placed on a sturdy work table and that side covers are not subject to damage.

10.2.1 SAFETY PRECAUTIONS



HEAVY OBJECT – 25 KG (55 LBS)

Ensure the Free Fall Device is secured during service to prevent accidental damage or injury from dropping.



CAUTION – SPRING LOADED PARTS

The webbing assembly is spring loaded and will rapidly return into the device if released. This may result in damage or injury.



MAGNETIC PARTS

The Free Fall Device contains strong magnets. Always ensure working environment is free of loose ferrous materials. Ingress of metal objects may compromise QuickFlight operation.

Always use genuine Head Rush Technologies replacement parts; any modifications without the expressed written consent of Head Rush Technologies are not allowed. Third party components should be inspected and serviced in accordance with that manufacturer's instructions. Supplemental instructions, demonstration videos, and inspection logs are available at headrushtech.com.

10.3 Daily Inspection

The daily webbing inspection must include at least a visual inspection sufficient to evaluate the wear and integrity of the device's webbing. Please see "Webbing Wear" below for a detailed description of when a webbing should be taken out of service. The inspection may be performed from the ground if the webbing can be adequately inspected.

10.3.1 UPPER WEBBING INSPECTION



INSPECT BOTH UPPER WEBBING LINES DAILY IN ACCORDANCE WITH THE FOLLOWING INSTRUCTIONS.

The Upper Webbing lines in the QuickFlight are wear components which require daily inspection and periodic replacement when they show signs of wear, damage, or contamination. More frequent inspection may be required for high throughput facilities or when operating in harsh environments. Refer to the Upper Webbing Wear Tables below for examples of acceptable and unacceptable wear of QuickFlight and QuickFlight XL Upper Webbing lines. These tables do not include all possible types of wear or damage. If in doubt, remove webbing from service. Webbing must be removed from service if it does not pass inspection. Refer to the Upper Webbing Wear Troubleshooting Table for possible causes of accelerated webbing wear. Continued use of webbing beyond stated limits may result in separation, disconnecting the Participant from the QuickFlight Free Fall Device.

To inspect the Upper Webbing lines, simultaneously extract the entire length of both lines from the device and carefully examine both edges and faces of each webbing for wear or damage including:



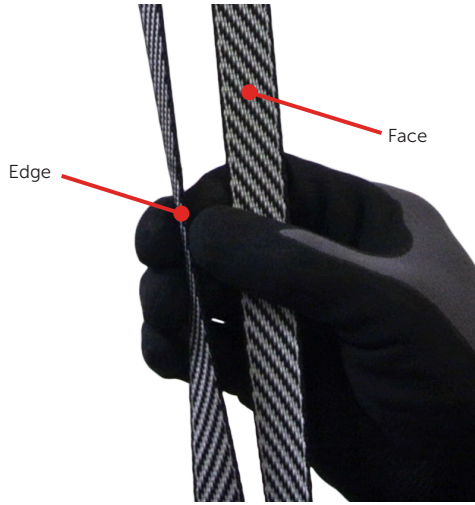



- Damage to stitching
- Cuts to the face or edges
- UV degradation including discoloration, fading, brittleness, or chalking
- Hard fibers
- Surface glazing or melting appearance
- Permanent deformation or warping
- Contamination from chemicals, dirt, grit, sand, dust, etc.

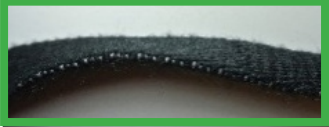
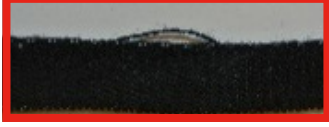
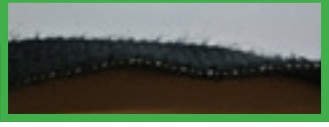
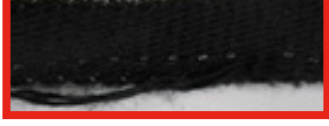

Webbing Inspection Surfaces

UPPER WEBBING WEAR TABLE - QUICKFLIGHT

Webbing pictures outlined in **red** in the tables below show webbing that **MUST** be taken out of service and replaced immediately to continue using the QuickFlight Free Fall Device. The **green** outlined photos show webbing that can be kept in operation.







QuickFlight		
Degree of Wear	Side Wear	Face Wear
NEW		
STAGE 1		
STAGE 2		
STAGE 3		
STAGE 4		

MOLDY WEBBING

Any webbing showing signs of mold should be taken out of service.

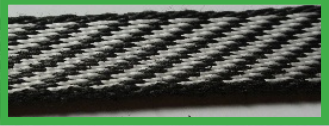
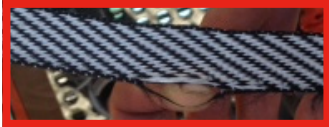
UPPER WEBBING WEAR TABLE - QUICKFLIGHT XL

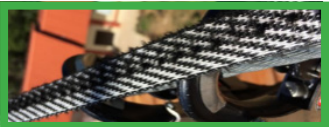
Webbing pictures outlined in **red** in the tables below show webbing that **MUST** be taken out of service and replaced immediately to continue using the QuickFlight Free Fall Device. The **green** outlined photos show webbing that can be kept in operation.

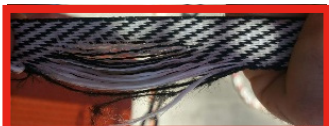
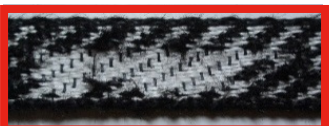
QuickFlight XL		
Degree of Wear	Side Wear	Face Wear
NEW		
STAGE 1		
STAGE 2		
STAGE 3		
STAGE 4		
STAGE 5		

MOLDY WEBBING

Any webbing showing signs of mold should be taken out of service.

WEBBING WEAR TROUBLESHOOTING TABLE

Symptoms	Potential Causes	Potential Solutions
WEBBING FACE WEAR SIDE WEAR & LOOP FAILURE	Participants are swinging excessively as they descend	Encourage Participants to step off the platform rather than jumping out. Participants should also jump vertically. Flailing motions (swinging arms and legs, leaning forward/back, etc.) can create more lateral movement.
	Foreign objects, including dirt and/or dust have introduced damage to nozzle stainless steel surface	Inspect nozzle for burrs and other damage. If damage is found, replace nozzle.
	QuickFlight is mounted incorrectly	Ensure that the QuickFlight is mounted according to the Operator Manual. Make sure that the QuickFlight is not angled. Always mount QuickFlight vertically with nozzle pointed down.
	Foreign objects, including dirt and/or dust have introduced damage to webbing assembly	Cover the QuickFlight when not in use. Wipe the webbing with a dry cloth daily, after use.
	Webbing is rubbing on obstruction	Move the obstruction so that it does not interfere with QuickFlight operation.
	Normal use of QuickFlight	Parts and webbing wear over time with normal operation, replace webbing as necessary.
UV FADED WEBBING	Sun is damaging webbing	Remove QuickFlight at the end of day or cover device and webbing after use.
JACKET DAMAGE	Participants are pulling down on QuickFlight jacket as they jump	Ensure that the RipCord webbing is installed with the OPA end toward the QuickFlight device. Coach Participants to hold only the hand grip of the RipCord webbing.
WEBBING IS MOLDY/ DISCOLORED	Webbing is not being dried after being used in wet conditions	Whenever using the QuickFlight in wet conditions, take the device down at the end of the day, extend the webbing in a sanitary environment, and allow webbing to dry outside of the device. Do not store in wet condition. Do not use heat to dry webbing.

10.3.2 RIPCORD WEBBING INSPECTION

The RipCord Webbing does not wear significantly under normal operation, but requires daily inspection for damage and degradation. Webbing must be removed from service if it does not pass inspection. Continued use of webbing beyond stated limits may result in separation, disconnecting the Participant from the QuickFlight Free Fall Device.

To inspect the RipCord Webbing, examine the entire length of the RipCord Webbing from Webbing Connection Rings to Carabiners and carefully examine the webbing and bar tacks for wear or damage including:

- Loose stitching or damage to stitching
- Cuts or abrasion damage to any part of the webbing assembly
- UV degradation including severe discoloration, fading, or chalking. Refer to the RipCord Webbing Degradation Table for replacement criteria due to UV degradation.
- Wear or damage to the Webbing Connection Rings or Carabiner attachment loops
- Hard fibers
- Permanent deformation or warping
- Contamination from chemicals, dirt, grit, sand, dust, etc.

The following mandatory checks must be performed each time the RipCord Webbing is inspected:

- **Bungee Integrity** - Hold the Carabiner end of the RipCord stationary and pull the bungee section tight. Check that the webbing covering the bungee section remains slack while the internal webbing is tight. If the outer webbing pulls tight, replace the RipCord.



RipCord Bungee Inspection

- **Overload Protection Assembly** - Inspect the OPA section of the RipCord Webbing, ensuring that the OPA is fully contained within the OPA Jacket. Open the OPA Jacket and inspect the internal webbing, bar

tacks, and stitching for damage. Check that the OPA Jacket is not damaged and that webbing is still clamped to the OPA Jacket and positioned so that the Jacket is centered between the bar tacks at the ends of the OPA section.



RipCord OPA Inspection



- **Activation Strip** - With the OPA Jacket open, find the Activation Strip and check it for structural integrity by pulling outward on the colored OPA webbing. Inspect the stitching for any broken threads. If broken threads are found, replace the RipCord. Reinstall the OPA into the OPA Jacket and close the zipper.



Activation Strip Inspection

RIPCORD WEBBING DEGRADATION TABLE

Webbing pictures outlined in **red** in the tables below show webbing that **MUST** be taken out of service and replaced immediately to continue using the QuickFlight Free Fall Device. The **green** outlined photos show webbing that can be kept in operation.

Degree of Wear	UV Damage
NEW	
STAGE 1	
STAGE 2	

10.4 Weekly Inspection

Once weekly, the condition of the device casing and side covers should be visually inspected for damage or corrosion. The weekly inspection may be carried out with the unit in place or removed to a sturdy work table. If operating in a salty or harsh environment, refer to Section: Side Cover Replacement to remove the side covers and visually inspect the internal components for corrosion. If red rust is found, the device should be immediately taken out of service and returned for recertification. White scaling is acceptable and does not require recertification. Reinstall the side covers after inspection.

The results of the Weekly Inspection should be documented on an inspection log. Weekly inspection logs are available for download at: <https://headrushtech.com/service/inspection-logs.html>.

1. **Device Condition** - Visually inspect the exterior of the QuickFlight casing for damage, corrosion, loose fittings and fasteners. Verify that all safety labels are in place and legible. Verify that the side covers are in place.
2. **Device Mount** - Inspect the QuickFlight mounting points and structure anchor points for damage and ensure device and mount are suitably secured.

3. **Mounting Hardware** - Check that all hardware used to connect the QuickFlight mounting points to the structure anchor points is in operational condition, secure, and free of corrosion.
4. **Webbing Extension and Retraction** - Check that the webbing extension and retraction is smooth and maintains resistance throughout its range.
5. **Upper Webbings** - Simultaneously, fully extend both Upper Webbing lines from the QuickFlight device. Check the condition of the lines, looking for damage or discoloration. Refer to Section: Upper Webbing Inspection for replacement criteria. If worn or damaged, replace with a new Upper Webbing assembly.
6. **RipCord Webbing** - Check the condition of the RipCord Webbing including the Overload Protection Assembly, looking for damage or discoloration. Refer to Section: RipCord Webbing Inspection for procedures and replacement criteria. If worn or damaged, replace with a new RipCord Webbing assembly.
7. **RipCord Connection Hardware** - Check that the Webbing Connection Rings used to connect the QuickFlight RipCord Webbing to the QuickFlight Upper Webbings are both fully closed and tightened according to the manufacturer's instructions. Inspect the rings for damage and replace if necessary. Head Rush Technologies allows the use of the Petzl Ring Open only to connect the RipCord Webbing to the Upper Webbings.
8. **Participant Connection Hardware** - Inspect the condition of the carabiners or other applicable Participant Connection Hardware, checking for excessive wear, damage, and correct operation of the locking mechanisms. If a carabiner gate does not automatically lock, lubricate the carabiner with dry graphite or dry PTFE based lubricant only until fully operational. Do not allow lubricant to come in contact with any webbing line. If full functionality of the locking mechanism cannot be restored, replace the carabiner.



IF A CARABINER IS DAMAGED OR UNSERVICEABLE, ONLY AN EN 362 CERTIFIED TRIPLE LOCKING CARABINER WITH LANYARD KEEPER MAY BE USED AS A REPLACEMENT CARABINER. HEAD RUSH TECHNOLOGIES RECOMMENDS THE USE OF THE PETZL AM'D CARABINER WITH CAPTIV LANYARD KEEPER.

9. **Lanyard Keepers** - Inspect the Lanyard Keepers, checking that they are not cracked or damaged, and that they maintain proper positioning of each Carabiner on the ends of the RipCord Webbing. Replace damaged or non-functional Lanyard Keepers.



Check for cracks or damage.

Inspection of Lanyard Keeper

10.5 Bi-Annual Inspection

The QuickFlight Free Fall Device requires an in depth six (6) month inspection by the Operator to maintain its safe and efficient operation. For the six monthly inspections the unit must be dismantled and removed to a sturdy work table.

10.5.1 INSPECTION PROCEDURE

1. Dismount the Free Fall Device (refer to Installation Instructions).
2. Clean Free Fall Device using a clean cloth.
3. Carry out Steps 1 through 6 of the 'Weekly Inspection'.
4. Remove the Nozzle – Refer to **'To remove the nozzle assembly'** section below.
5. Inspect Nozzle Assembly for the following:
 - Excessive wear to slot, which could affect retraction of the webbing.
 - Splitting, cracking and deformation.
 - Correct fit in housing.

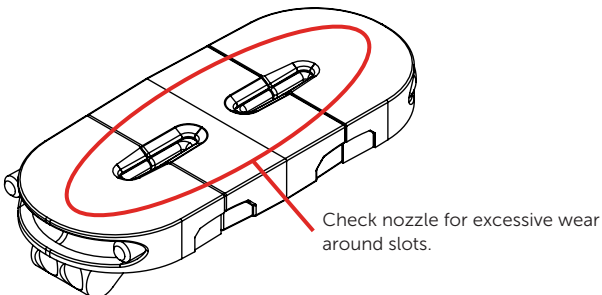

Inspection of Nozzle

ANNUAL RECERTIFICATION



OPERATION OF THE QUICKFLIGHT FREE FALL DEVICE WITHOUT A CURRENT CERTIFICATION LABEL VISIBLE WILL RENDER THE DEVICE NOT FIT FOR USE AND VOID THE WARRANTY. CONTINUED OPERATION PAST THE "NEXT RECERT REQUIRED" DATE MAY RESULT IN SERIOUS INJURY OR DEATH.

The QuickFlight Free Fall Device requires an annual service and recertification inspection to be carried out by an authorized Service Center. The QuickFlight device should be packaged in its original protective foam and box to safeguard the device from damage during shipping.

The Certification expiration date is shown on the Certification Label located on the device casing. Dismount the QuickFlight Free Fall Device and return to an Authorized Service Center prior to the Next Recertification Date shown. Document the orientation and connection details prior to dismantling the device to aid reinstallation.

head rush
technologies

SERIAL NUMBER:

MANUFACTURE DATE: / /

RECERTIFICATION DATE: / /

NEXT RECERT REQUIRED: / /

BY:

10024-01

"Next Recert Required" Date Shown Here

10.6 Upper Webbing Replacement

Replacement of an Upper Webbing assembly may be carried out with the QuickFlight in place or removed and secured to a workbench.

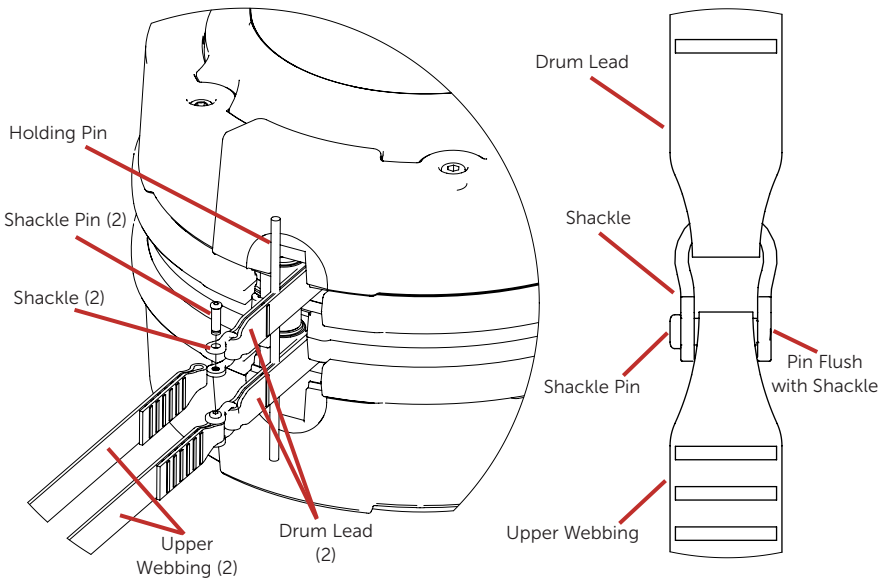

Drum Lead Diagram

To replace an Upper Webbing:

1. Disconnect the Webbing Connection Ring from the Upper Webbing being replaced.
2. Remove the nozzle assembly.
3. Simultaneously extract the entire length of both Upper Webbing including their drum leads.
4. Insert a suitable holding pin through the loops in the drum leads above the shackle. This will prevent the lines from retracting back into the device.



IF EITHER DRUM LEAD RETRACTS BACK INTO THE DEVICE, THE DEVICE WILL REQUIRE SERVICE BY AN AUTHORIZED SERVICE CENTER.

5. Unscrew the shackle pin of the webbing to be replaced and remove the webbing. Discard the old shackle pin. Cut off the ends of the used Upper Webbing before discarding to ensure it is not accidentally re-used.



ALWAYS USE A NEW SHACKLE PIN PROVIDED WITH THE WEBBING REPLACEMENT KIT. NEW SHACKLE PINS COME WITH THREAD LOCKING COMPOUND THAT CAN ONLY BE USED ONCE.

6. Install the new Upper Webbing and new Shackle Pin, ensuring the shackle loop is fitted to the drum lead and shackle pin to the end of the webbing. Ensure that the new webbing assembly is correct for the device model, mounting configuration, and RipCord configuration.
7. Tighten the shackle pin until fully seated.
8. Remove the holding pin and allow the Upper Webbing lines to slowly retract without twisting until the drum leads and sewn webbing ends are inside the device.



TWISTED WEBBING WITHIN THE DEVICE MAY CAUSE THE NOZZLE ASSEMBLY TO DISCONNECT FROM THE DEVICE CASING, LEADING TO SUDDEN AND EXTREME WEBBING WEAR, WEBBING SEPARATION, SERIOUS INJURY, OR DEATH.

9. Replace the nozzle assembly.
10. Allow the webbing lines to slowly retract into the device without twisting while maintaining constant tension. Ensure the retraction force is smooth and adequate resistance is felt.
11. Once the webbing lines are fully retracted, pull hard on both lines at once, extracting a short length (~1m) of webbing. Repeat up to three times to ensure that the dual webbings are equally stretched and tightly wound onto the drum.
12. Ensure that one Upper Webbing is fully retracted and that the other Upper Webbing is no more than 0.3m (1 ft) extracted from the nozzle.
13. Connect the colored end of the Upper Webbing to the Webbing Connection Ring that was previously disconnected, following the manufacturer's instructions to ensure that the Connection Ring is properly closed. Ensure that there are no twists between the RipCord Webbing and the Upper Webbings.
14. If necessary, reinstall the QuickFlight to its properly mounted position.

10.7 Nozzle Replacement

The nozzle assembly is located on the QuickFlight device casing and provides guidance for the dual Upper Webbing during extraction/retraction. The nozzle assembly is a wear component and will need to be inspected regularly; replacement is on a conditional basis. Service of the nozzle assembly may be carried out with the QuickFlight in place or removed and secured to a workbench.

To remove the nozzle assembly:

1. Secure or hold the webbing lines to prevent them from retracting into the device when the nozzle is removed.
2. Extract the U-shaped nozzle pin using a flat head screwdriver or comparable tool.
3. Remove the three nozzle pieces.
4. To re-install the nozzle assembly, reverse the above steps, ensuring that the webbing lines do not become twisted.

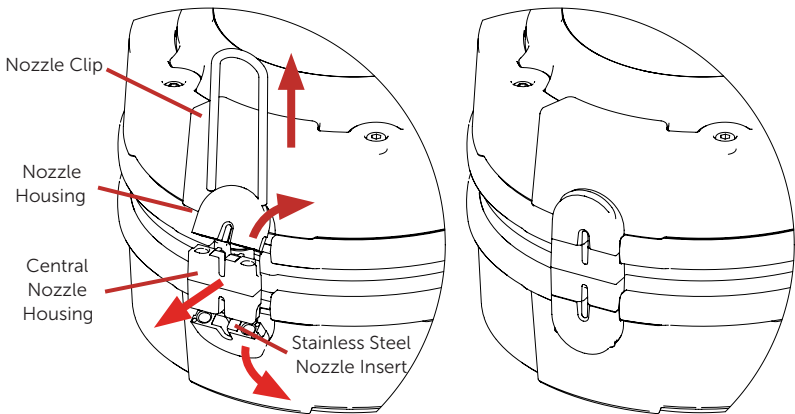

Nozzle Replacement Diagram (Webbing not shown)



DO NOT OPERATE THE QUICKFLIGHT FREE FALL DEVICE WITHOUT THE NOZZLE ASSEMBLY PROPERLY INSTALLED.



NOZZLES ARE WEBBING SPECIFIC. QUICKFLIGHT DOES NOT USE THE SAME NOZZLE AS THE QUICKFLIGHT XL. USE THE APPROPRIATE NOZZLE FOR YOUR SPECIFIC MODEL. INCORRECTLY USING A QUICKFLIGHT NOZZLE WITH A QUICKFLIGHT XL CAN RESULT IN ACCELERATED WEBBING WEAR. IF NOZZLE REQUIRES REPLACEMENT ALWAYS REPLACE AS A MATCHED THREE-PART SET – DO NOT MIX WORN AND NEW NOZZLE PIECES.

10.8 Side Cover Replacement

The QuickFlight Free Fall Device side covers are removable and simply snap into place on the device casing. Remove side covers by placing a flat head screwdriver under the edge of the cover and carefully levering it up. To replace, align the outer profile of the side cover with the profile of the casing and snap into place.



DO NOT OPERATE THE QUICKFLIGHT FREE FALL DEVICE WITH SIDE COVERS REMOVED.

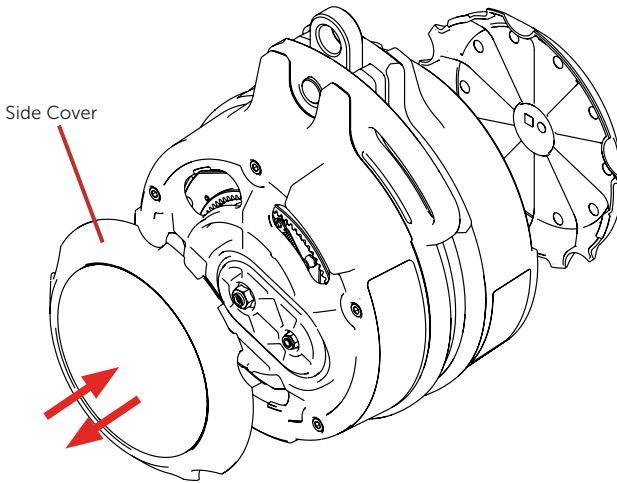

Side Cover Replacement Diagram

10.9 RipCord Webbing Replacement

Replacement of a RipCord Webbing assembly may be carried out with the QuickFlight in place or removed and secured to a workbench.

To replace a RipCord Webbing:

1. Disconnect both Webbing Connection Rings from their respective Upper Webbings.
2. Cut the connection points off of the RipCord Webbing to ensure it is not accidentally re-used.
3. Discard the RipCord Webbing and all associated Webbing Connection Rings, Carabiners, and other connectors unless the manufacturer's instructions allow for longer-term use.



ALUMINUM CARABINERS AND RINGS HAVE A LIMITED LIFESPAN AND SHOULD BE RETIRED FROM SERVICE WHEN THE RIPCORD WEBBING IS REPLACED.

4. Open the Webbing Connection Rings on the new RipCord Webbing.
5. Connect the Webbing Connection Rings so that they each join one RipCord attachment point to one Upper Webbing attachment point. Ensure that the OPA end of the RipCord Webbing is attached to the Upper Webbings, and that the hand grip and carabiners are positioned away from the device. It does not matter which Connection Ring goes to which Upper Webbing.
6. Close the Webbing Connection Rings on the new RipCord according to the Manufacturer's instructions.

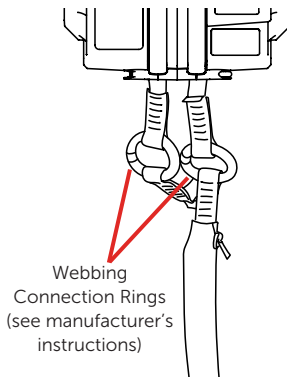

Webbing Connection Ring Diagram

10.10 Long Term Storage

If the QuickFlight Free Fall Device is to be placed into storage or left unused for longer than two weeks, ensure the device and all webbing components are clean and dry and protected from the environment. Ensure the Upper Webbing is fully retracted into the device. Always store in a clean, cool, and dry environment, preferably in the original packaging. Upon re-installation of the device, perform the Daily, Weekly, and Bi-Annual Inspections if appropriate.

After exposure to water or damp conditions, thoroughly clean and dry the QuickFlight prior to storage. Ensure that the QuickFlight is not left with a wet webbing inside the casing as this may result in corrosion of the device and deterioration of the webbing. To dry the webbing / device, remove the side covers and fully extend the wet webbing assembly and allow to completely dry in a clean environment prior to storing the device. Ensure that debris does not enter the device when side covers are removed. Re-install the side covers prior to storing or using the device.



DO NOT STORE THE QUICKFLIGHT, UPPER WEBBINGS, RIPCORD WEBBING, OR ASSOCIATED COMPONENTS IN A WET CONDITION. STORAGE MUST BE IN A CLEAN, COOL, AND DRY ENVIRONMENT IN ACCORDANCE WITH THESE INSTRUCTIONS.



NEVER USE HEAT TO DRY THE WEBBING OR DEVICE. DO NOT USE SOLVENTS OR ABRASIVES WHEN CLEANING QUICKFLIGHT COMPONENTS, WEBBINGS, AND ASSOCIATED EQUIPMENT.

Improper Operation



THE FOLLOWING SCENARIOS ARE NOT ALLOWABLE, MAY CAUSE DEVICE DAMAGE, AND CREATE A DANGEROUS SCENARIO WHICH COULD RESULT IN EQUIPMENT DAMAGE, SERIOUS INJURY, OR DEATH.

- Pulling webbing out of the device before descent for additional free fall.
- Descending from the platform with a running start.
- Descending on the device with a higher weight than the device maximum.
- Using multiple devices simultaneously to accommodate weights above the maximum.
- Lowering more than one participant at a time. The QuickFlight Free Fall Device is designed to lower only one participant at a time.

10.11 Replacement Parts

Your QuickFlight Free Fall Device is fitted with a number of user replaceable parts that may be refitted without the need to return the device to an authorized Service Center. Always follow the Manufacturer's instructions as detailed in this Operator Manual and any Part Replacement Guide supplied when undertaking replacement of a part.



NOTE

Only use genuine QuickFlight parts and accessories.

To order replacement parts or accessories, contact your authorized Distributor or go to <https://store.headrushtech.com>.

10.12 Troubleshooting

Refer to <http://headrushtech.com/troubleshooting> for troubleshooting instructions or contact your authorized Distributor or Service Center.

10.13 Transportation

To ensure safe shipment of your QuickFlight, it should only be shipped in an authorized QuickFlight packaging (box and packing material). If you have misplaced your original packaging, purchase replacement packaging from an authorized Distributor or Service Center, or online at <https://store.headrushtech.com>. You will be responsible for the cost of any damage and necessary repairs due to shipping your QuickFlight in unauthorized packaging.



CARE FOR THE ENVIRONMENT

Reuse the original packaging when shipping Free Fall Device.

11.0 MANUFACTURER'S DETAILS

For Recertification or unscheduled service or repairs, return your QuickFlight Free Fall Device to your nearest Head Rush Technologies Authorized Service Center or to the Manufacturer at the address shown below.

ADDRESS

Head Rush Technologies
1699 Cherry St. Suite C
Louisville, CO 80027
USA

CONTACT DETAILS

+1-720-565-6885
www.headrushtech.com
info@headrushtech.com

To find a Service Center outside the U.S., visit headrushtech.com/distributors/service-centers.

EU importers may apply their name and address on the device to comply with government regulations next to the specification label.



TAKE FLIGHT



REGISTER YOUR DEVICE

Get automatic updates on recertification and product information – visit headrushtech.com/register

ANNUAL RECERTIFICATION IS REQUIRED

Please keep the shipping box for your device. For instructions on annual recertification, visit headrushtech.com/recertification

+1-720-565-6885

www.headrushtech.com

info@headrushtech.com

April 2026